

PIPE



Size mm	Code	Length	Colour	Qty
32	KP104	4m	W B	10
40	KP204	4m	W B	10
50	KP304	4m	W B	5

Double spigot

STRAIGHT COUPLINGS

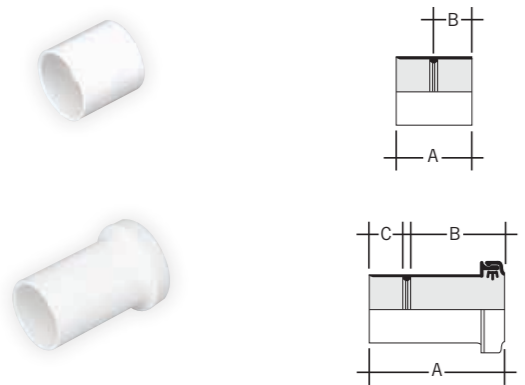

Size mm	Code	A	B	Colour	Qty
32	KSC1	46	20	W B	60
40	KSC2	53	24	W B	30
50	KSC3	66	28	W B	30

Size mm	Code	A	B	C	Colour	Qty
32	KEC1	86	61	20	W	10
40	KEC2	90	64	23	W	10
50	KEC3	82	50	30	W	10

Expansion/adaptor

PIPE CLIPS

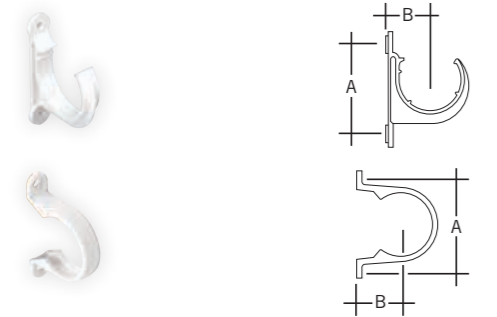

Size mm	Code	A	B	Colour	Qty
32	KF1	57	30	W B G	100
40	KF2	62	30	W B G	100
50	KF3	77	41	W B G	80

Open clip

Size mm	Code	A	B	Colour	Qty
32	WC3	76	30	W B	100
40	WC4	82	30	W B	100
50	WC5	100	38	W	80

Closed clip

BENDS

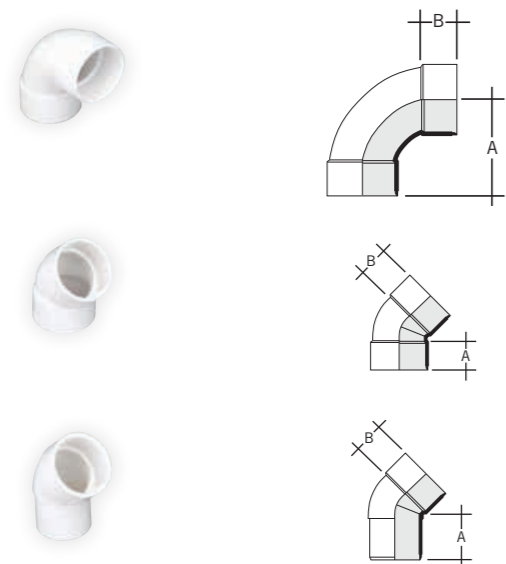

Size mm	Code	Angle	A	B	Colour	Qty
32	KB1	88½°	57	18	W B	50
40	KB2	88½°	62	21	W B	30
50	KB3	88½°	78	28	W B	10

Size mm	Code	Angle	A	B	Colour	Qty
32	KB12	45°	29	18	W B	10
40	KB22	45°	33	21	W B	20
50	KB32	45°	42	28	W B	20

Size mm	Code	Angle	A	w	Colour	Qty
32	KBA12	45°	24	23	W	40
40	KBA22	45°	35	26	W	20
50	KBA32	45°	39	30	W B G	20

Spigot

BENDS

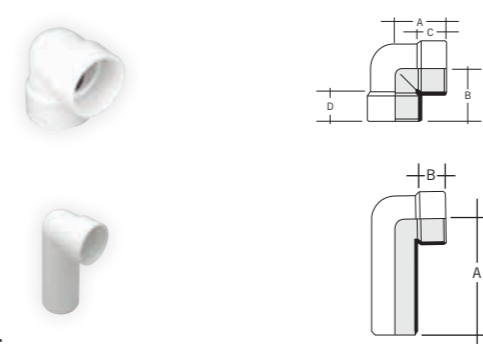

Size mm	Code	Angle	A	B	C	D	Colour	Qty
40	KBK25	90°	48	48	23	23	W B	20
50	KBK35	90°	59	50	20	28	W	10

Knuckle bend/boss adaptor, which can solvent weld over a boss upstand

Size mm	Code	Angle	A	B	Colour	Qty
32	KBS1	87½°	92	18	W	20
40	KBS2	87½°	92	23	W	20
50	KBS3	87½°	92	30	W B G	10

Solvent socket/spigot

TEES

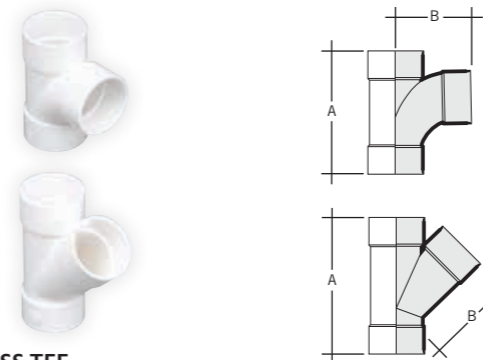

Size mm	Code	Angle	A	B	Colour	Qty
32	KT1	88½°	92	57	W B	30
40	KT2	88½°	106	62	W B	20
50	KT3	88½°	135	78	W B	10

Size mm	Code	Angle	A	B	Colour	Qty
40	KT21	45°	117	78	W	20
50	KT31	45°	149	100	W	10

CROSS TEE

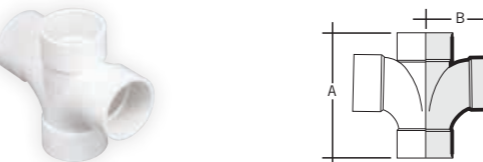

Size mm	Code	Angle	A	B	Colour	Qty
40	KXT21	88½°	106	62	W	10
50	KXT31	88½°	140	87	W	10

ACCESS PLUG

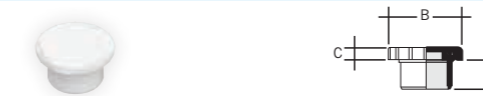

Size mm	Code	A	B	C	Colour	Qty
32	KAP1	22	53	8	W B	10
40	KAP2	25	57	8	W B	10
50	KAP3	33	71	8	W B	10

SOCKET REDUCER



Size mm	Code	A	B	Colour	Qty
32-21.5	KR175	22	20	W	100
40-32	KR210	28	22	W B	80
50-32	KR310	32	28	W	40
50-40	KR320	32	28	W B	40

IRON ADAPTORS

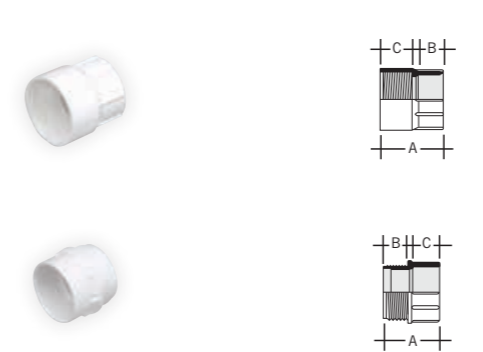

Female

Size mm	Code	A	B	C	Colour	Qty
32	KFA1	50	25	20	W	10
40	KFA2	53	25	24	W	10
50	KFA3	60	25	28	W	10

Solvent socket/BSP thread

Male

Size mm	Code	A	B	C	Colour	Qty
32	KMA1	44	20	20	W	50
40	KMA2	47	20	24	W	40
50	KMA3	53	20	28	W	40

Solvent socket/BSP thread